

Þórý Veðardóttir's guide to Drawing & Resizing Heraldry for Non-Artists



Hello! My name is Þórý, which is said like 'Story!' with more Thor. My pronouns are they/them.

This class will show you how to take your Heraldic Submission Paperwork and resize it to be painted, embroidered, stamped, or otherwise reproduced. You will be cutting and tracing, so you will have excellent results even if you can't draw. Spoiler: I'm a mediocre artist. I trace.

There are two options for resizing, both with a photocopier and physical copying and pasting, and digital resizing.

TL;DR: How to make patterns with →

This class uses simple terms instead of Proper Heraldic Language. My goal in the Society is to make Heraldry accessible to everyone.

HeraldicArt.org

Facebook.com/vedardottir

Middlewiki.midrealm.org/index.php/Talk:Thor_y_Vedardottir

East
College of Heraldry
Society Name Þórý Veðardóttir

Legal name
Address
Branch Name
Phone Number Date of Birth
E-mail Address Date Submitted
Consulting Herald Herald's E-mail/Phone

This name is (pick one):
 already registered
 submitted with this device
 previously submitted from the Kingdom of

Action Type
 New
 Resubmission
 Kingdom
 Laurel
 Change, if registered:
 release old device
 retain as badge
 Appeal (attach justification)
 Other (specify)

Proposed Blazon (Consult a herald if possible. Use plain English if you don't know how to blazon.)
Azure, a winged ounce within an orle argent.

Instructions: Send 1 black and white outline and one color copy to Blue Tiger Herald (name and address in the Pikestaff). Make checks payable to "SCA, Inc. - East Kingdom."

(Note: the shield shape should be approximately 5 inches (12.7 cm) wide and 6 inches (15.2 cm) tall when printed)

	Amount Received	Date Received	Action Taken	Amount Forwarded	Date Forwarded
Kingdom					
Laurel					

The journey starts at Staples (or another copy center)

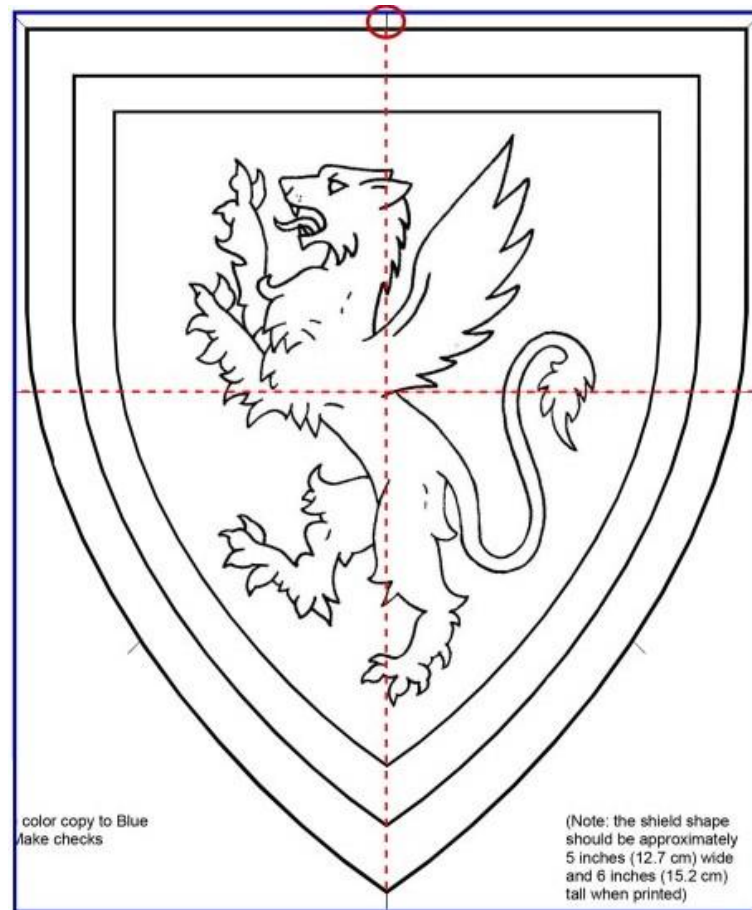

1. Photocopy your Heraldic Form.
2. Notice the tic marks surrounding the shield. They are artists' guides and can make enlarging your Heraldry easier.
3. Cut your Heraldry out so you're only enlarging your design, not the paperwork.
4. Most copiers align to the upper left corner of the scanner bed. Check the machine you use.
5. Most photocopiers have a size limit to what they can enlarge. Staples' limit is 400% - if you need more than that, enlarge the enlargement.

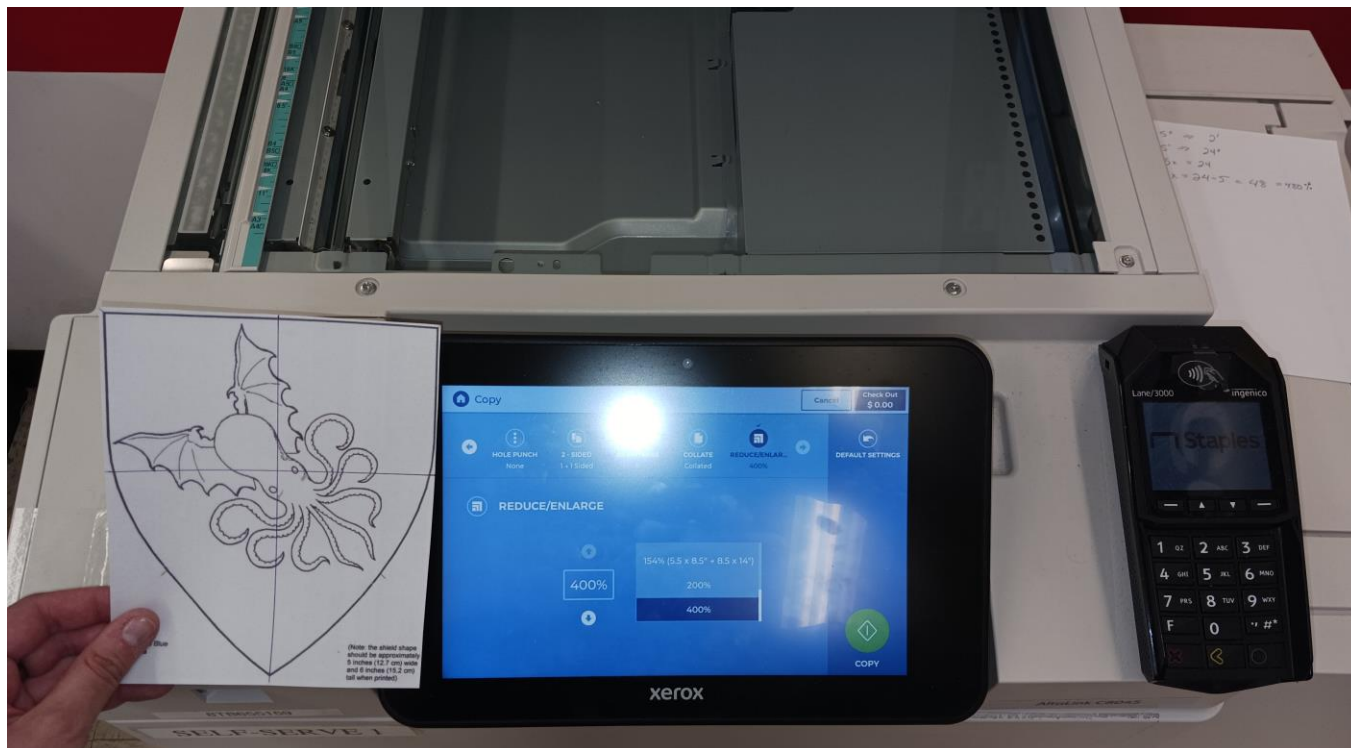

Putting it all together (but not with staples!)



1. One option Staples copiers offer is 11x17" paper. This is helpful in making patterns of large banners and shields.
2. If you can fit your enlargement on two or four sheets of paper, this is easy. If you need a larger version, add more lines and keep making it bigger.
3. Cut off everything outside the lines and tape both sides together. This is critical because you will be cutting your pattern. Be sure to save every piece of paper!

Don't Panic! We're going to do some math.

The size of your design on heraldic paperwork is 5" by 6".

You will need to determine the goal dimensions of your pattern size. List tree shields are about 10" by 12" whereas many combat shields are roughly 24" wide. Verify your dimensions with a measuring tape!

For a 24" wide shield, you will need to increase the 5 inch paperwork x percent. So the equation is $5y = 24$. To find y , divide each side by 5.

$24 \div 5$ is 4.8. To convert that to a percentage you can type into a photocopier, multiply the result by 100%. So $4.8 \times 100 = 480\%$

$$\frac{24}{5} = 4.8 \quad 4.8 \times 100\% = 480\%$$

If you needed 36" (three foot) height as your vertical dimension, you use the 6" side length on the heraldic paperwork. The equation will look like this:

$$\frac{36}{6} = 6 \quad 6 \times 100\% = 600\%$$

Drawing the Design Digitally

Inkscape is an Open Source, completely free vector drawing program used by many heralds and scadian designers. One feature is that you can set your page size! You can print files that have only lines –and no solid colors!– as Blueprints at Staples. You want the Outline version from your paperwork.

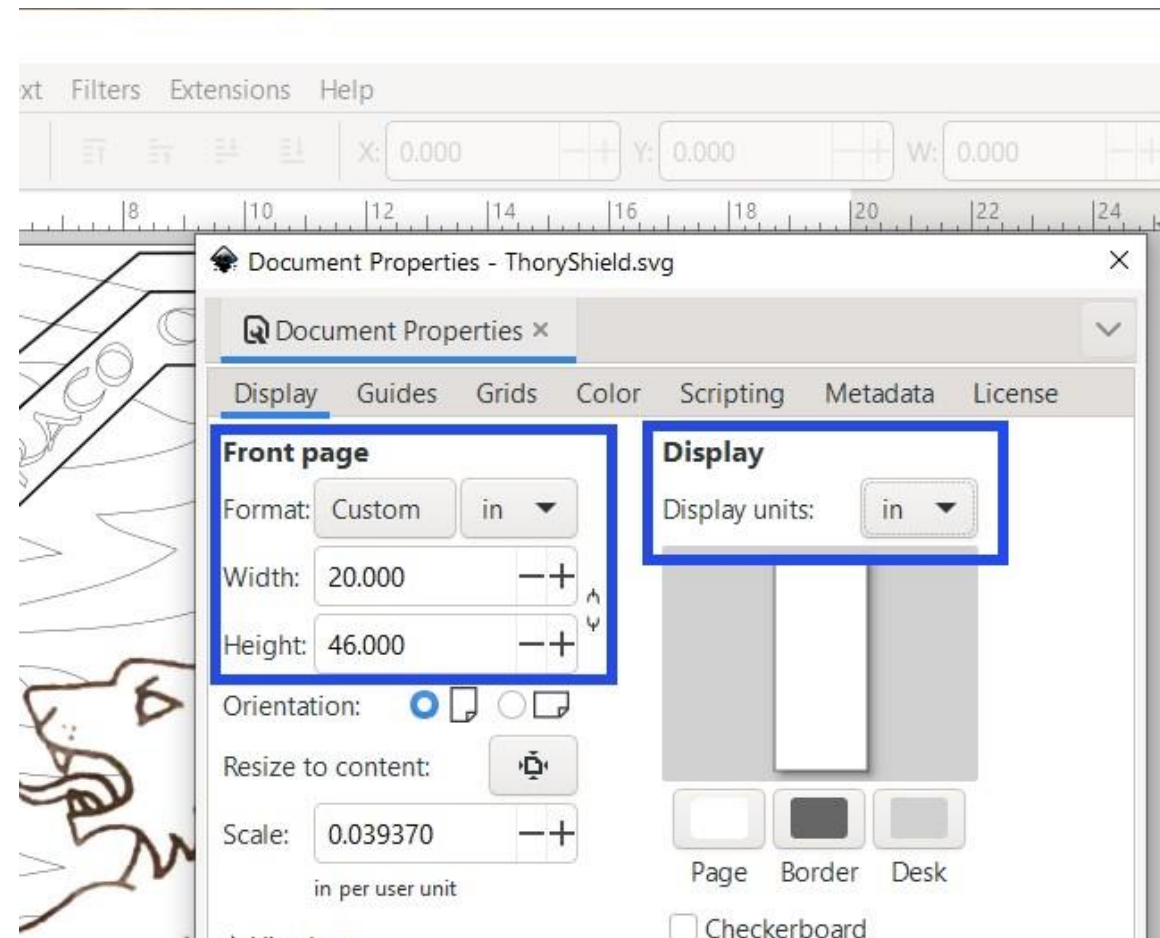
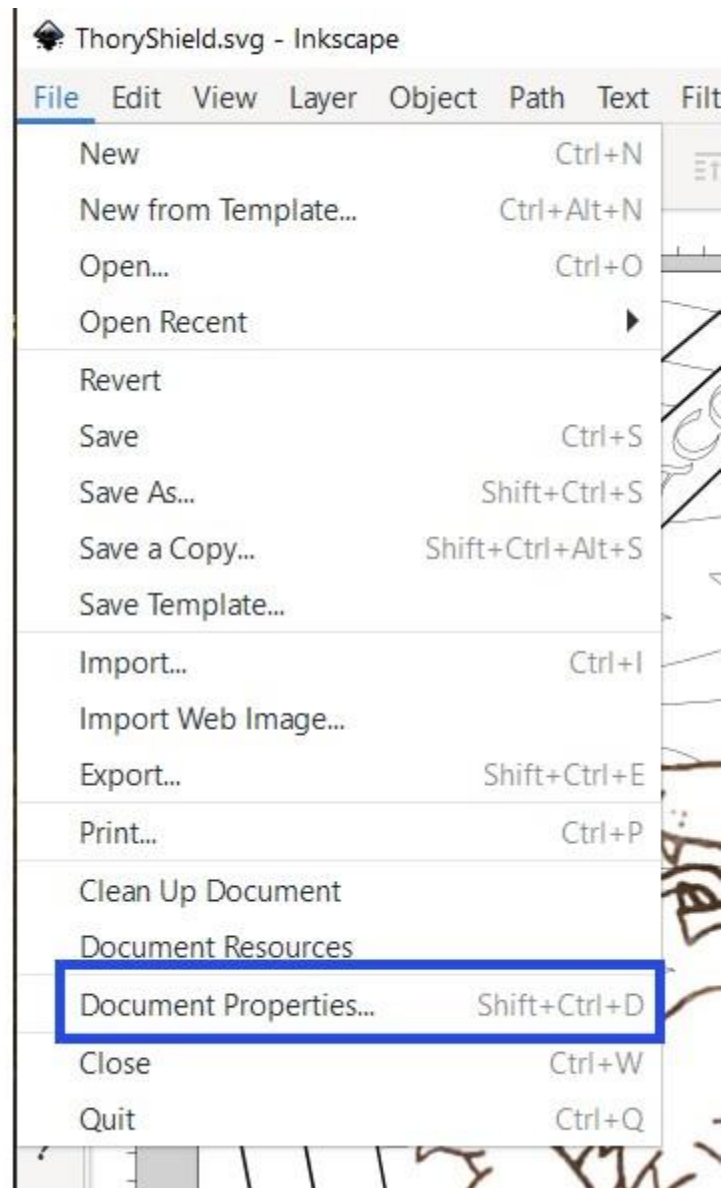

If you plan to bring your design to Staples, you will need to save it as a PDF and make sure it is not resized to fit smaller paper.

<https://inkscape.org>

Resizing for Smaller Selections

Most of the resizing I do is for large displays, but these techniques work just as easily for shrinking images. Scribes often use 1" or 1.5" tall shields on scrolls, and if you're embroidering a belt favor or hood, you will need smaller versions of heraldic art. If you struggle with a certain size, you can make the document that size, add your image, draw a box, and then change the document size to 8.5x11 to print.

If you're not sure what size you'll need, you can print a variety of image sizes and choose what works best. The HeraldicArt.org database is designed to accommodate a variety of sizes for this reason.

Height	Percent
1"	17%
1.5"	25%
2"	33%
3"	50%
4"	67%
5"	83%

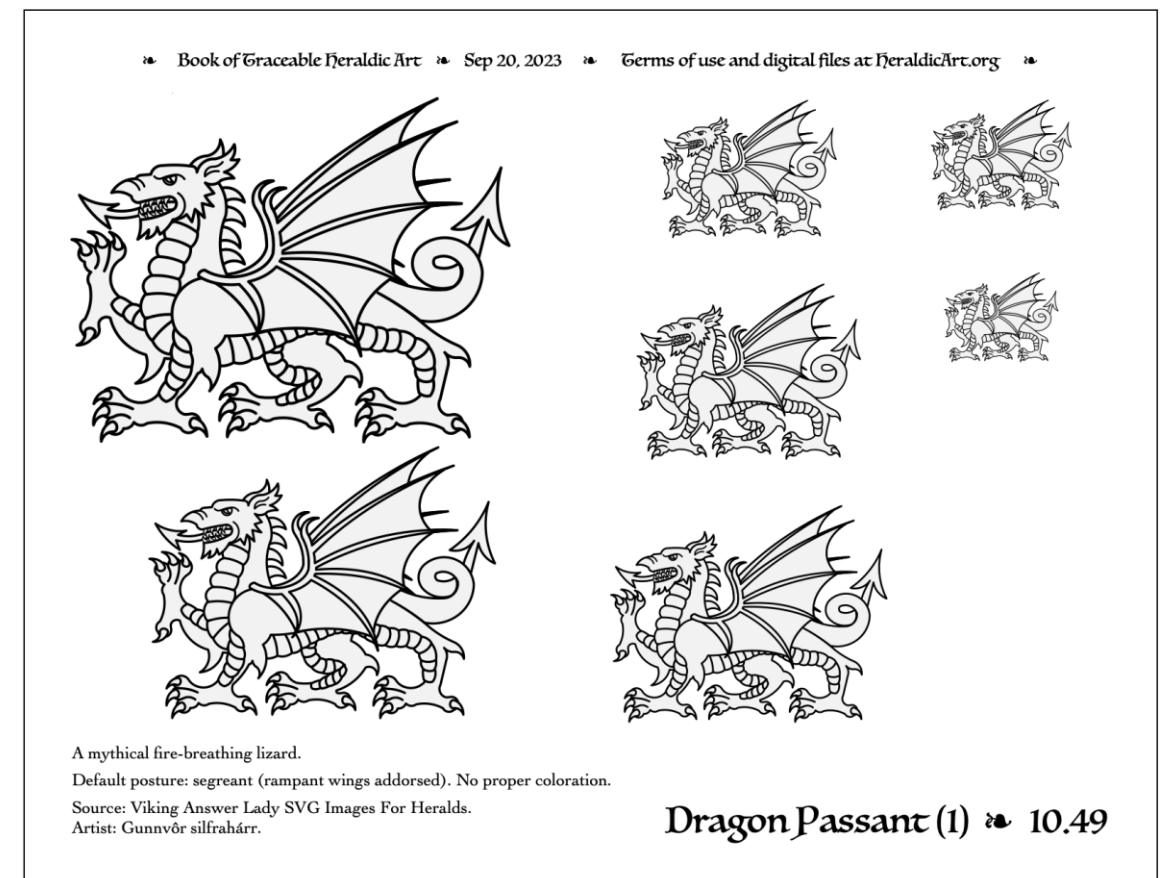
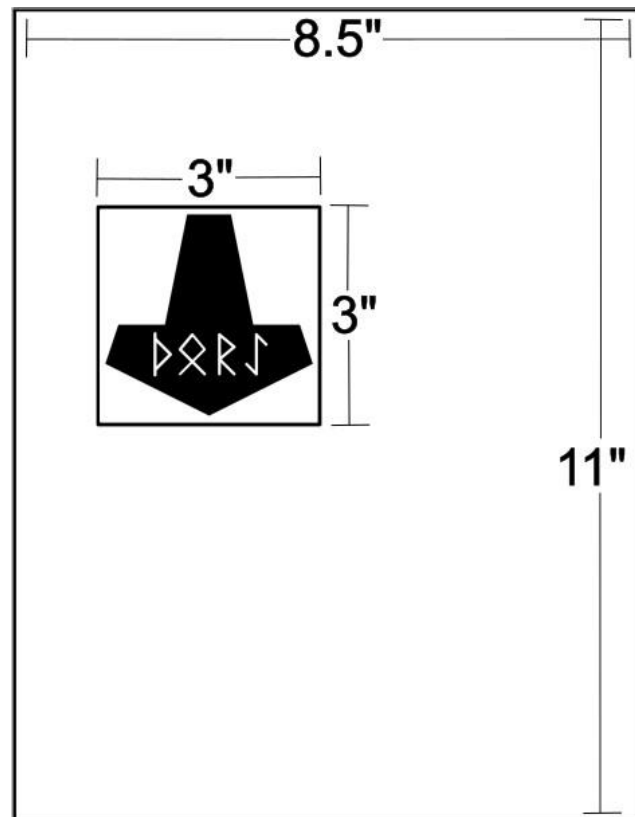

Careful Cut Outs

Once you have your printed heraldry in its Final Form, the real work begins: cutting out the design. I have a variety of medium and small scissors for cutting paper designs, and for the fiddly bits like claws or teeth, I use a pair of nail scissors.

Be careful when you cut your pattern, making sure you keep the “extra” blank space. You’ll need that on hand to help you align the objects in the space. These photos show my work in progress embroidery, using the cat as the template to cut my fabric and the extra space for alignment.

Disclaimer: I am not responsible for wrath incurred if you cut a paper pattern with Sewing Scissors!



Tracing: Not Actually Terrible

Once your pattern is cut out, you will need to trace it onto the canvas for painting. If your piece is flat, you can tape the main piece directly onto the canvas and paint around the edges. My shield is curved, so I had to trace the design onto it with a pencil. I stopped often to verify that my cat wasn't being distorted and the lines of the orle border were straight.



If you are tracing your design with pencil, I cannot recommend a white plastic eraser enough. Pink erasers leave colored streaks on paper and canvas.



HeatnBond[®]
iron-on adhesive **ULTRAHOLD**



NO STEAM REQUIRED
MACHINE WASHABLE

Recommended Materials

For applique work like my Heraldic Dress and smaller pieces, I swear by HeatnBond. It will fuse the pieces of fabric together, allowing you to just finish the edges with a satin stitch.

For all painting needs, I swear by LiquiTex. Panther Primitives recommends it for tent painting, and I use it for banners, shields, and even tabards. If you add fabric medium to the paint, you will have machine washable tabards. It can be watered to create shading effects.

